



Date
Quote #
Project Name
Type



## STEPLIGHTS - Wall Recessed

### Description:

Cast aluminum face plate with a abricated aluminum back box. Lens is silicone sealed to door frame for weather protection. All external hardware is stainless steel.

Name	Engine	Lumens	CCT	Electrical	Mounting	Lens	Pattern	Options	Finish
<input type="text"/>	<input type="text"/>	<input type="text"/>	<input type="text"/>	<input type="text"/>	<input type="text"/>	<input type="text"/>	<input type="text"/>	<input type="text"/>	<input type="text"/>

Name	Light Engine	Source Lumens <sub>(LED)(5000K)</sub>	Color Temp	Electrical
SCSL	12 LED (Max)	1560	3000K	UNV 120-277V
SFSL			3500K	HLV 347-480V
SGSL			4000K	
SBSL			5000K	
SLSL				

*For better illustration of face designs see {page 2}*

*Contact for custom*

*Contact for custom*

*Contact for custom*

Mounting	Lens	Light Pattern	Options	Finishes
R Recessed in dry wall	OAL Opal acrylic lens (Std)	F Front light	DF Double face	BL Black
RTC Recessed in concrete	FG Frosted glass lens		TS Tamperproof screws	WH White
			TP Tamperproof hardware	SG Silver Grey
			SF Single fuse	BZ Bronze
			EM Emergency battery	CC Custom Color
			RB Remote ballast/driver	See website for custom colors. Contact factory for physical samples.

- Lumens are based on max wattage & 5000K CCT
- IES files available upon request
- Std - Standard Offering





**Dimensions & Mounting:**

Please note that drawings are not to scale.

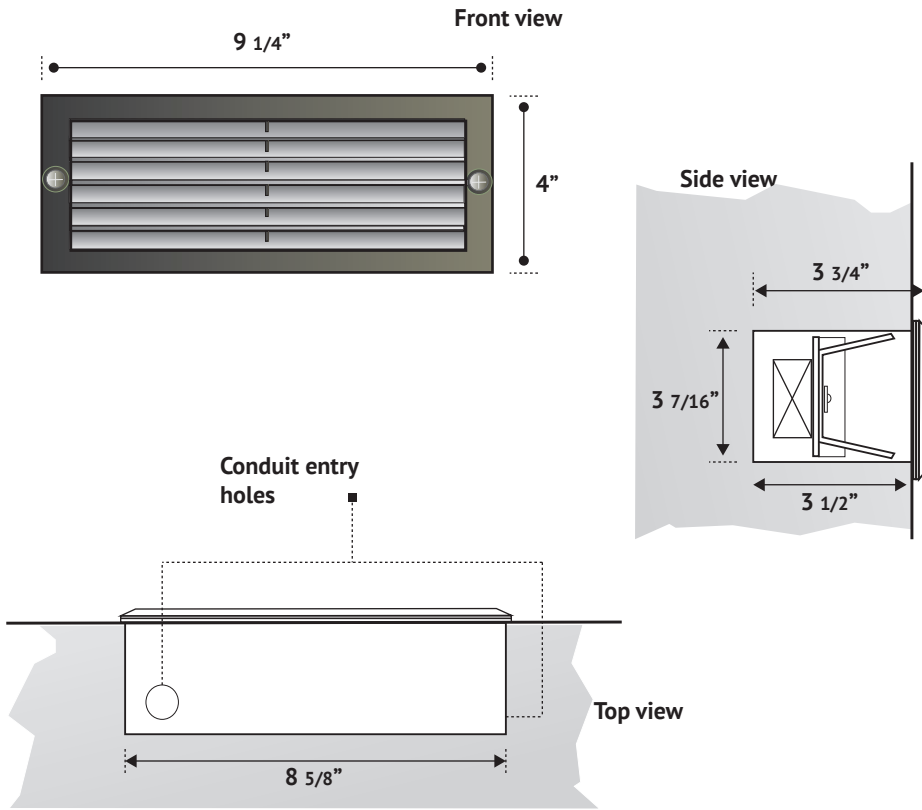

**Face designs**

- SCSL (Standard)
- SFSL
- SGSL
- SBSL
- SLSL

Custom face designs available contact factory

**Listing:**

Complies to CSA and UL standards.

**Polar Graph:**

