



Date
Quote #
Project Name
Type



SONIC - Pendant

Description:

SONIC is made of an aluminum frame and a silicone sealed lens. Colored acrylic disc louvers (see finishes) surround the lens creating a lantern shape.

Name - Engine - Lumens - CCT - Electrical - Mounting - Lens - Pattern - Options - Finish

Name	Light Engine	Source Lumens _{(LED)(5000K)}	Color Temp	Electrical
SONIC-26	26 20 LED (Max)	3520	2700K	UNV 120-277V
SONIC-36	36 30 LED (Max)	5280	3000K	HLV 347-480V
SONIC-48	48 40 LED (Max)	7040	3500K	
			4000K	
			5000K	
	Contact for custom	Contact for custom	Contact for custom	

Mounting	Lens	Light Pattern	Options	Finishes
P96 96" pendant stem (Std)	OAL Opal acrylic lens (Std)	EG Encompassing glow (Std)	DM 0-10V dimming	Standard Aluminum framework only
CLU Cluster mount (contact factory)		UD Up and down light	DM1 1% dimming	BL Black
WM Wall mount			SV Swivel canopy	WH White
				SG Silver Grey
				BZ Bronze
				Select disc louver color
				YAL Yellow acrylic louvers
				RAL Red acrylic louvers
				GAL Green acrylic louvers
				BAL Blue acrylic louvers
				Custom
				CC Custom Color
				See website for custom colors. Contact factory for physical samples.

- Lumens are based on max wattage & 5000K CCT
- IES files available upon request
- Std - Standard Offering





Dimensions & Mounting:

Please note that drawings are not to scale.

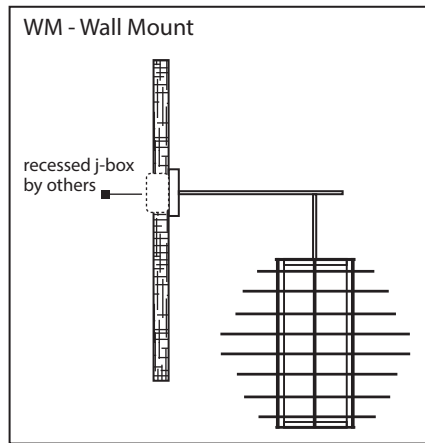
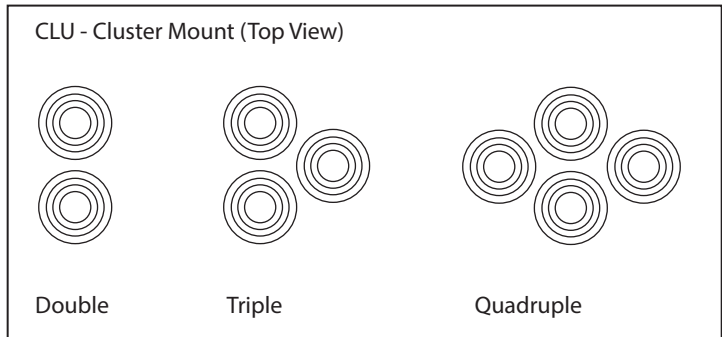
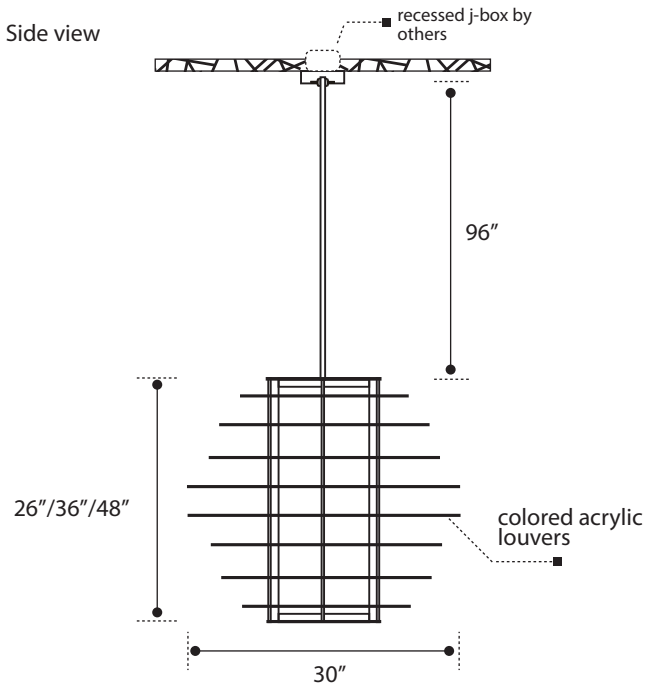

Listing:

Complies to CSA and UL standards.

Polar Graph:

