

Date:
Type:
Project:



GSC – WALL MOUNT

DESCRIPTION:

The housing is made from precision molded die cast aluminum. The 0.124" thick back plate works as a heat sink for the electrical components.

Name	Light Engine	Source Lumens*	Color Temp	Electrical		Mounting	
GSC	48W LED	6240	3000K	UNV	120-277V	WM	Wall Mount
	150MH	Contact for custom	4000K	HLV	347-480V		
	175MH		5000K	TT	Tri-Tap (HID)		
	2PLT57		MT	Multi-Tap (HID)			
	Contact for other wattages		Specify other				

Lens		Light Pattern		Options		Finishes	
CG	Clear Glass Lens (Std)	D	Down Light	PC	Button Photocell	BL	Black
FG	Frosted Glass Lens			AEL	Quartz Restrike	WH	White
OPL	Opal Polycarbonate Lens			RB	Remote Ballast/Driver	SG	Silver Gray
				EM	Emergency Battery	BZ	Bronze
				WL	Wet location	See finishes for custom in website	
				TP	Tamperproof hardware		

*Lumens are based on Max Wattage and 5000K CCT
 Std – Standard Offering
 IES files available upon request

GSC - _ _ _ _ _

Customization Notes:

▶▶▶ Info on this spec sheet will change without notice as product development is an ongoing process.
 Date modified: 07/30/2021

Dimensions & Mounting (drawings are not to scale)

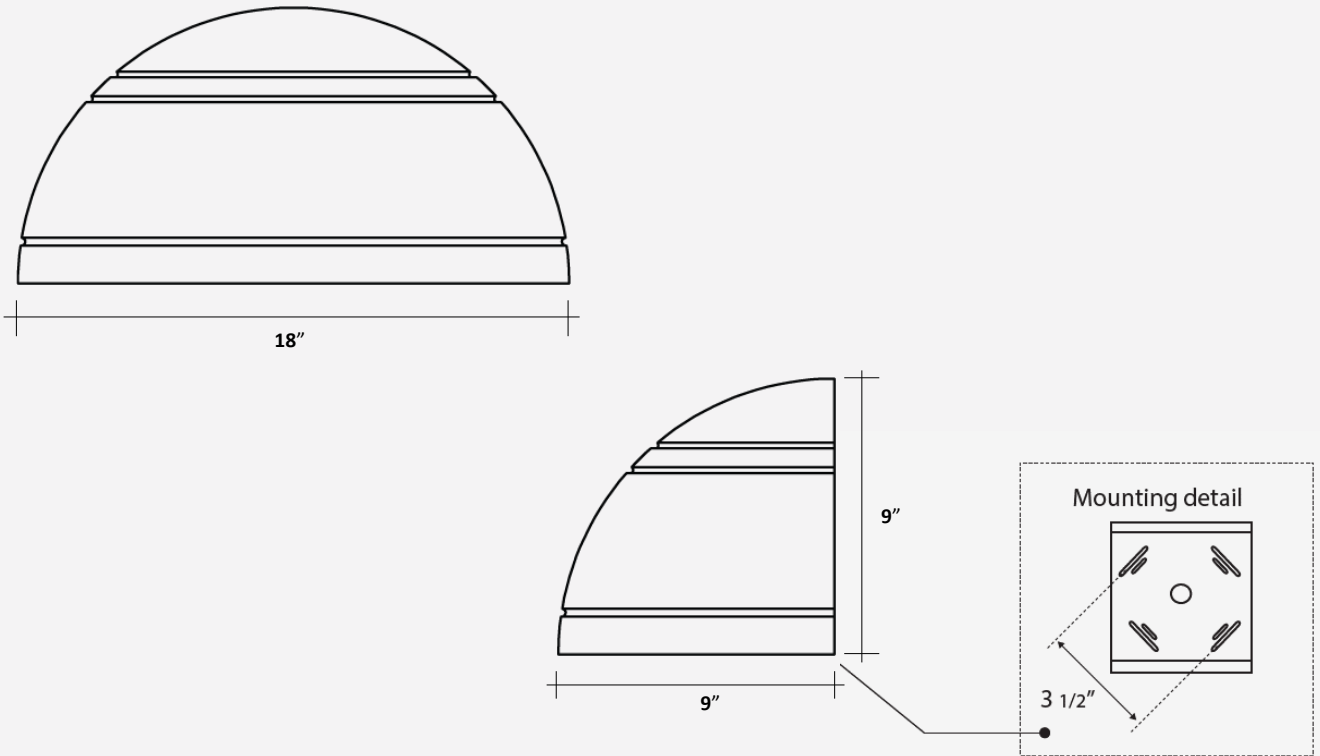

Polar Graph

